

# INSTALLATION MANUAL

36002

ecolight

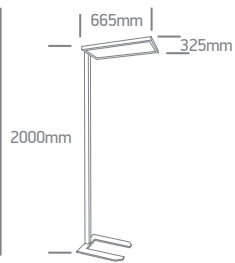

230V | 60W | IP20 | Touch switch | Aluminium

Complete with 2 x 700mA drivers

UGR17 | 80 CRI

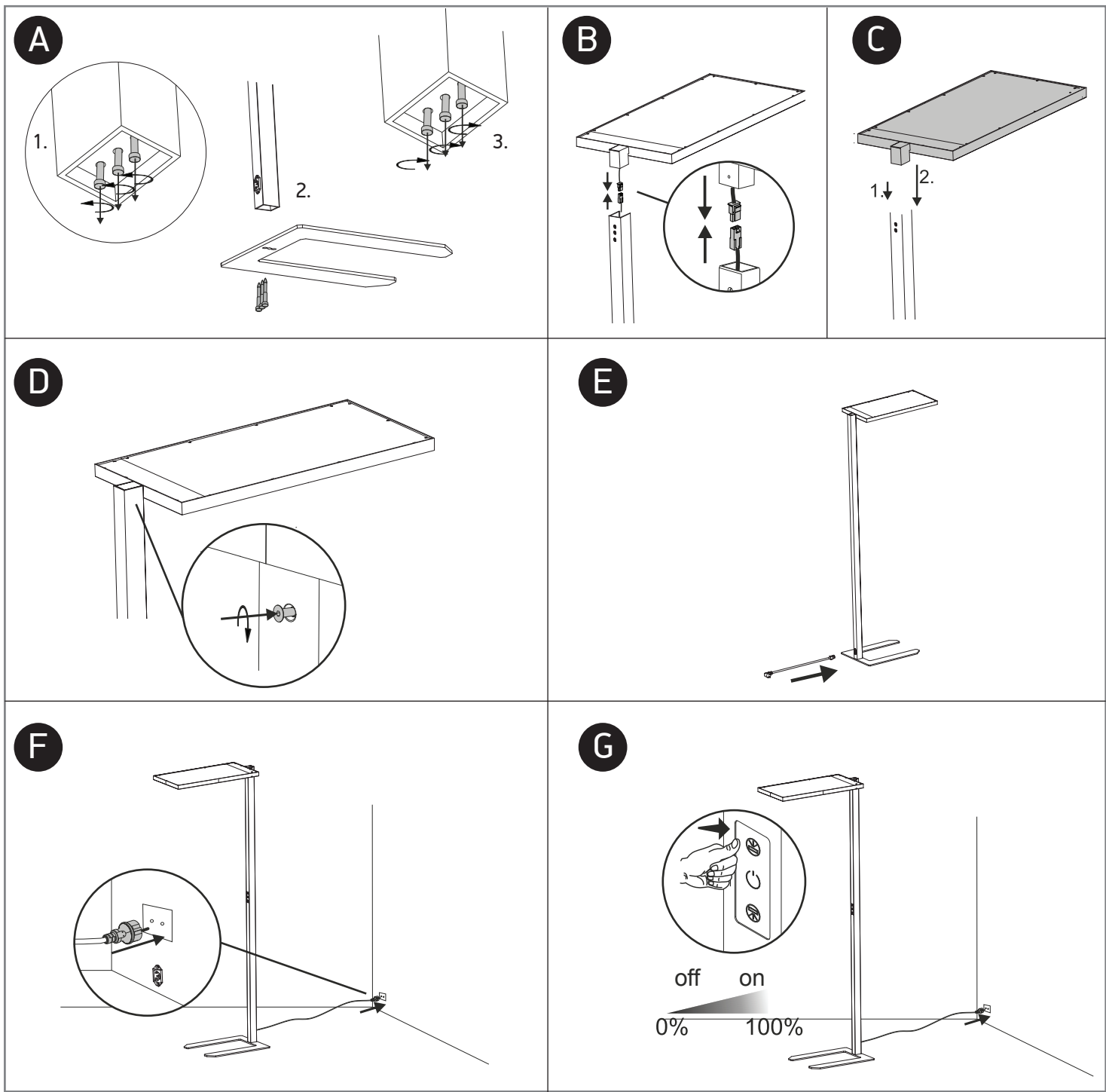

## Warnings:

1. Make sure that the product is installed properly before connecting to electricity.
2. Do not cover the fitting.
3. Maintenance and installation should only be carried out by a professional electrician.